

COT-V812I

Lens Groover

User's Manual



Read and understand the user's manual before using the machine and keep it handy for ready reference when you need.

**Standard Accessories List**

Item Name	Quantity
Sponge	1
Chuck Rubber	2
Water Kettle	1
Drain Plug	1
Belt	1
Chuck	1

**Components and functions**

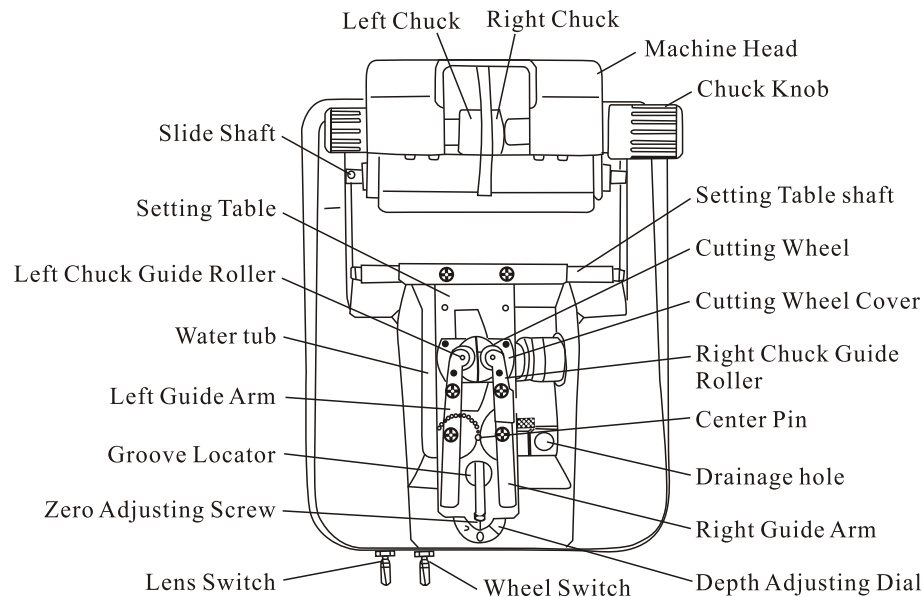

(1).Machine head

Raise the head vertically when setting or detaching a lens and when the instrument is stopped.

The head can lightly slide right and left.

Clean the slide shaft and apply oil to it if necessary.

Caution:

Do not switch ON the WHEEL switch until a lens is set. Otherwise, the water splashes. Also, never touch the cutter wheel rotating at a high speed.

(2).Lens Switch

The lens set to the instrument starts rotating when switched ON.

(3).Wheel Switch

The cutting wheel rotates when switched ON.

(4).Water Tub and Drainage Hole

Water is always necessary when grooving a lens. Water is supplied to the cutter wheel with the sponge. Proper water level in the water tub is approx. 5mm. Water is not successfully supplied to the cutter when the sponge is very dirty. In such case, take the sponge out of its case and wash it in water. Also, when replacing the sponge with a new one, soak sufficient water to it in water beforehand. When the water tub has dried out, operate the instrument after confirming that water is replenished and the sponge is sufficiently moistened.

Use the attached water kettle for supplying and draining the water.

Do not put excess water into the water tub.

If the water enters the internal bearing part, the instrument may be damaged and outputting high-pitched sound. And, drain all the remaining

water in side the water tub when changing the position of the instrument.

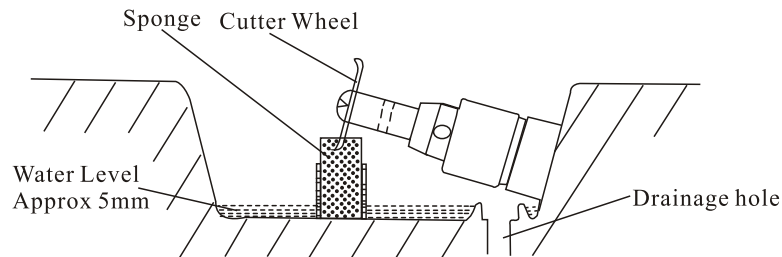

**Caution:**

Before supplying the water into the water tub, switch OFF the LENS switch and the WHEEL switch and pull out the power cord from the wall outlet.

**(5).Left Chuck,Right Chuck**

The left chuck is used for automatic centering, stable chucking and rotating. The Right Chuck is used to chuck up a lens with its Convex surface. (The Convex surface of the lens, please see the indicating icon of the Machine Head.)

**(6).Chuck Knob**

Used to chuck up and release a lens. (Do not tighten more than necessary.)

**(7).Depth Adjusting Dial**

Determines the depth to be grooved. 1 scale corresponds to 0.1mm. The maximum grooving depth is 0.7mm.

**(8).Guide Arm**

The guide rollers open to hold a lens when this side of the guide arm is gripped. The guide rollers guide the rotation of a lens. Parts are connected with the coupling pins and spring on the rear side of the setting table so that they function properly.

**(9).Center pin**

Insert and use the center pin when performing the lens edge center groover. Do not insert it too strongly. Pull out the center pin when performing the outer periphery profile grooving or the inner periphery profile grooving.

**(10).Zero Adjusting Screw**

Adjusts the basic “0” depth for the depth adjusting dial.

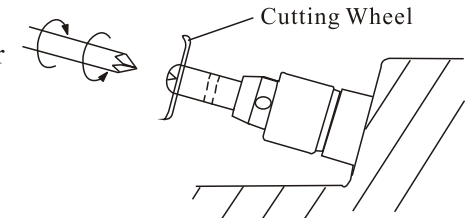

**(11).Cutting Wheel**

Groove the edge of a lens. Take caution not to bend or drop the cutting wheel since it is very precise. (Replacing of the cutter wheel, respectively.)

**(12).Setting Table**

Incorporates the lens guiding mechanism, the groove positioning mechanism, and the grooving depth adjusting mechanism, etc.

**Preparation before operation**

**(1).Choose a Type of Grooving**

Before a kind of lens is grooved, which type of grooving is to be chosen should be decided. Raise the setting table and under it, arrange a controllable system of installation of the machine, which should be in accordance with the following instructions and figures. In this way, you can get your desirable effect.

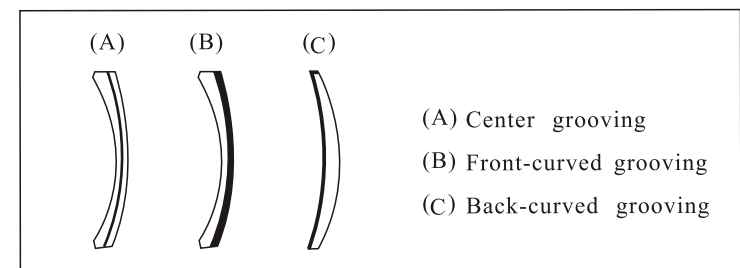

**<1-1>.Center Grooving**

Operating the setting table

1).Set the coupling pins on the rear side of the setting table to the position “ ← C → ”

2).Lightly insert the center pin into the center base hole.

3).Set the position of the groove locator to the center.

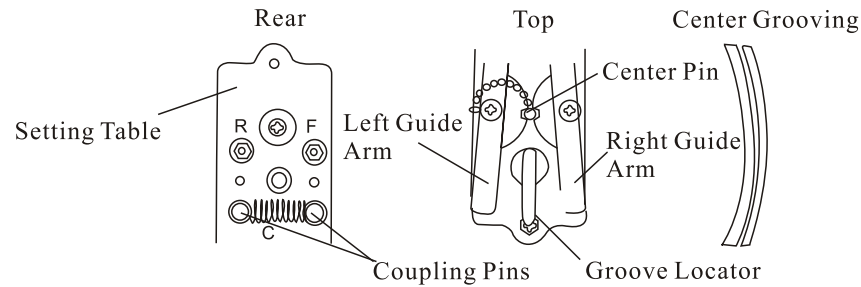

Do not insert the center pin too strongly.

Confirming the grooving position

- 1).Chuck the center part of a lens.
- 2).Grip the guide arm to open the guide rollers,and lower the lens slowly.
- 3).Set the grooving depth adjusting dial to “1-2” .
- 4).Switch ON the LENS switch,and confirm the grooving position by the line slightly grooved on the thin portion of a lens.
- 5).Adjust the grooving position when the grooving line is too close to the front or back surface of the lens,by adjusting the angle of the guide rollers.

Grooving a lens

After confirming the grooving position,once set the depth adjusting dial back to zero(0),switch ON the WHEEL switch to groove a lens,once again set the depth adjusting dial to the required depth.

<1-2>.Front Curve Grooving

Operating the setting table

- 1).Set the coupling pins on the rear side of the setting table to the position “F” as show in the figure below.
- 2).Remove the center pin from the center base.
- 3).Turn the groove locator in the arrow direction in the figure below, fit the cam of the groove locator to the right guide arm,and determine the position of a lens.

Operation of Setting Table

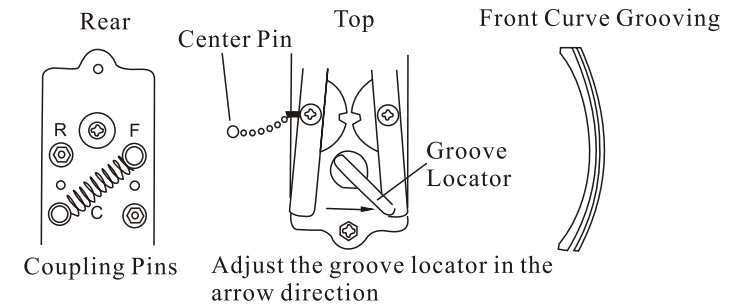

Grooving a lens

- 1).Chuck the center of a lens.
- 2).Open the left guide arm based on the portion where the lens edge is thin,lightly fit the front surface of the lens to the right guide roller,and lower the lens slowly.(The right guide roller works as a fixed roller.)
- 3).Then,groove a lens in the manner same as in Section<1-1> “Center Grooving” .

<1-3>.Rear Curve Grooving

Operating the setting table

- 1).Set the coupling pins on the rear side of the setting table to the position “R” as show in the figure below.
- 2).Remove the center pin from the center base.
- 3).Turn the groove locator in the arrow direction in the figure below, fit the cam of the groove locator to the left guide arm,and determine the position of a lens.

Operation of Setting Table

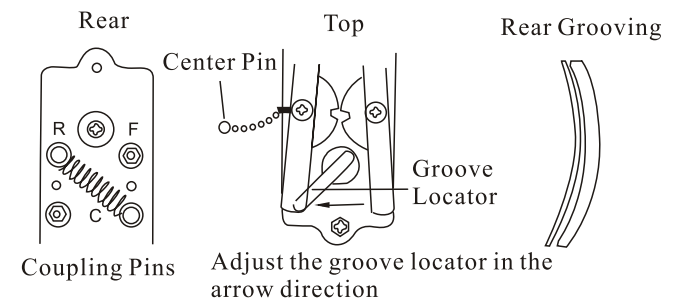

Grooving a lens

1) Chuck the center of a lens.

2). Open the left guide arm based on the portion where the lens edge is thin. lightly fit the front surface of the lens to the left guide roller, and lower the lens slowly. (The left guide roller works as a fixed roller.)

3) Then, groove a lens in the manner same as in Section <1-1> “Center Grooving” .

<1-4>. Grooving a Lens with Thin Edge

When grooving a Lens with thin edge, the thickness is not less than 1mm. First, machine a shallow groove and then machine a deep groove.

(2). Reference Position of Guide Roller

The reference of the left/right guide roller is the center of the dome cover of the cutter wheel, and the gap between the left and right rollers is 0.1-0.3mm.

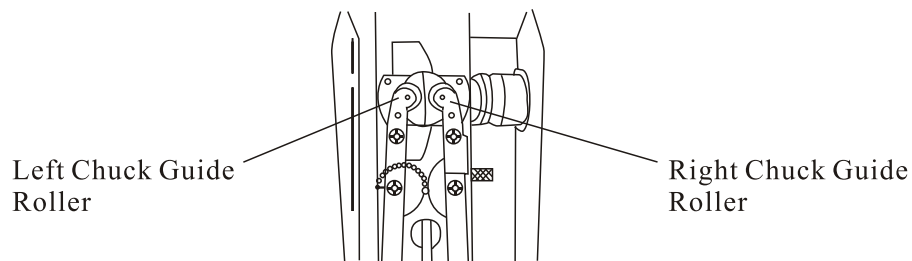

(3). Basic Grooving Position

<3-1>. Method to Move Grooving Position toward Front Surface of Lens

Turn the right adjusting knob to your body side as shown, when you want to move the grooving position of a lens toward the front surface. (Grooving position moves 0.5mm by one turning of the adjusting knob.)

Return the guide roller to its original position after grooving is complete.

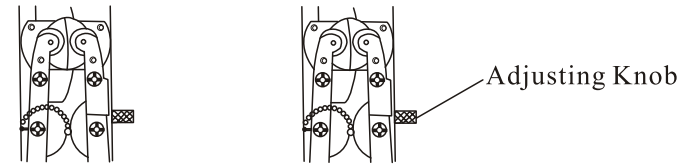
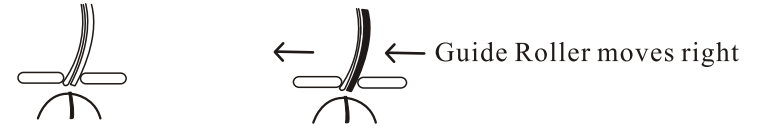

<3-2>. Method to Follow Lens Curve

Weak curve lens      Standard curve lens      Strong curve lens

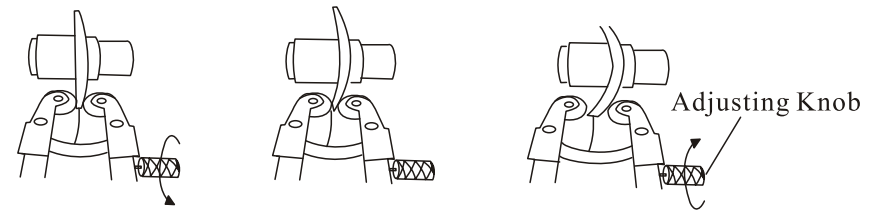

Guide Roller moves left

Guide Roller moves right

<3-3>. Method to Match Lens Types

High-power minus lens      Ordinary lens      High-power plus lens

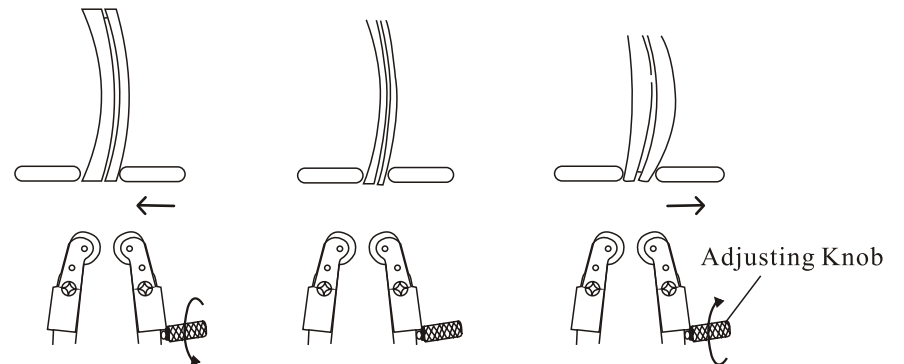

### Maintenance

#### (1).Dressing of cutter Wheel

When the cutter wheel becomes dull,dress the cutter wheel with the dressing stick in the following procedures:

<1-1>.Raise the setting table,supply water the sponge sufficiently and soak the dressing stick(#400)with sufficient water.

<1-2>.Rotate the cutter wheel and press the dressing stick onto the edge of the cutter wheel straight down for a few seconds(for a couple of times).

#### (2).Replacing of Cutter Wheel

Replace the cutter wheel in the following procedures:

Lift the setting table and lean it down backward and replace the cutter wheel,as shown in the figure below.

The cutter wheel is manufactured highly accurate.Dropping or bending the cutter wheel will cause deviation while it operates.

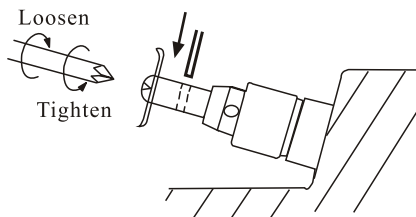

After the cutter wheel is replaced, adjust the zero adjusting screw,and set the zero position again.

#### (3).Cleaning and Lubrication of Head Slide Shaft

The machine head is a structure to slide right and left.Regularly wipe dirt and dust off the slide shaft with a clean,dry cloth.Besides,apply machine oil when the movement of the machine head becomes harder.

#### (4).Adjustment of Zero Adjusting Screw

Adjust the lens grooving depth with this zero adjusting screw.

Adjust this adjusting screw when the grooving depth is insufficient even with the scale set a 7 due to the wear of the cutter wheel.

For the adjustment,set the depth adjusting dial to zero(0)and place a lens to the wheel dome cover and then adjust the height with the zero adjusting screw to the level where the lens slightly touch the edge of the cutter wheel when the cutter rotates.

### Technical Parameters

Item	Specifications
Grooving depth	0-0.7mm
Grooving width	0.55-0.6mm
Lens edge thickness	1.2-11.0mm
Lens diameter	22-60mm
Time required for grooving	Approx. 20 sec/rev
Outside dimension	170(W) × 210(D) × 150(H)mm
Weight	2.7kg
Rated power supply	115VAC ± 10%,50Hz/60Hz,
	220VAC ± 10%,50Hz/60Hz,
Rated power consumption	95W
Rated time of continuous operation	15min
Rotating speed of cutter	5500rpm

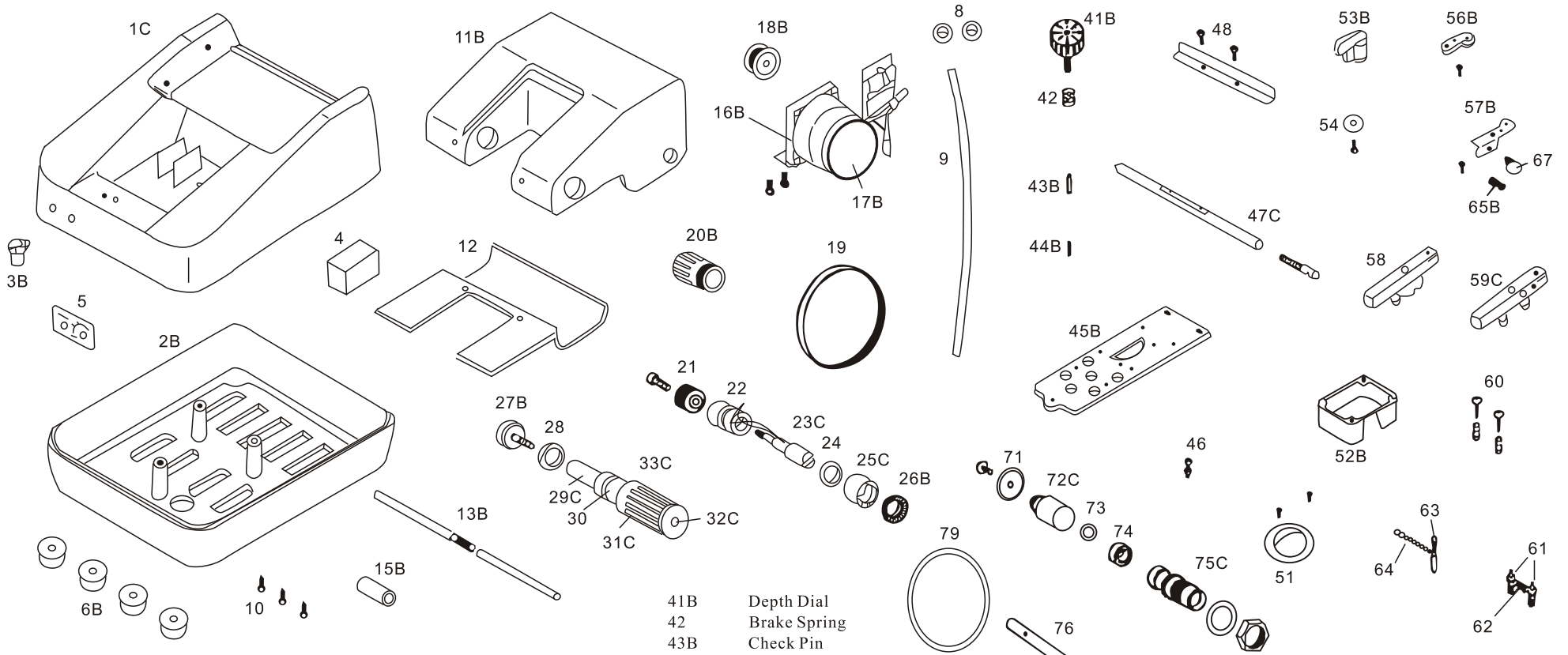

**PARTS LIST**

**LENS GROOVER COT-V812I**

Model	PARTS NAME
1C	Upper Casing
2B	Lower Casing
3B	Drain Plug
4	Sponge
5	Switch Panel
6B	Rubber Foot
8	Cord Bushing
9	Cord Tube
10	Setscrew
11B	Head
12	Head Bottom Plate
13B	Slide Shaft
15B	Slide Shaft Bearing
16B	Chuck Motor Bracket
17B	Chuck Motor
18B	Chuck Motor
19	Chuck Belt
20B	Left Knob
21	Left Shaft Pulley
22	Left Bearing
23C	Left Shaft
24	Left Seal
25C	Left Chuck
26B	Chuck Rubber
27B	Right Chuck
28	Right Seal
29C	Right Shaft
30	Right Bearing
31C	Chuck Knob
32C	Lock Screw
33C	Right Shaft Assembly (#29C to 32C)
41B	Depth Dial
42	Brake Spring
43B	Check Pin
44B	Push Spring
45B	Setting Table
46	Zero Adjuster
47C	Setting Table Shaft
48	Splash Shield
51	Lens Acceptor
52B	Splash Fence
53B	Groove Locator
54	Spring Washer
56B	Left Guide Roller
57B	Right Guide Roller
58	Left Guide Arm
59C	Right Guide Arm
60	Guide Arm Shaft
61	Coupling Pin
62	Coupling Spring
63	Center Pin
64	Chain
65B	Adjusting Knob
67	Adjusting Knob
71	Cutter Wheel
72C	Shaft Collar
73	Spring Washer
74	Bearing(#688zz)
75C	Cutter Shaft Barrel
76	Cutter Shaft
77	Bearing(#696zz)
78	Cutter Pulley
79	Cutter Belt
80	Main Motor
81C	Main Motor Bracket
82	Main Motor Pulley
83	Switch
84	Power Cord w/Plug
85	Syringe
87	Support Plate